

REV	DATE	DESCRIPTION	ECO	BY	CHK.
F	10/05/2014 00:00:00 AM	ADDED CATALOG NUMBER YA28TC14	38025	AS	MB

CATALOG NUMBER	STRANDED COPPER CONDUCTOR ACCOMMODATED			BOLT SIZE	METRIC BOLT SIZE	DIMENSIONS							
	CODE (AWG)	NAVY	METRIC SIZE (CLASS 2)			B	C	K DIA.	L	N	O.D.	T REF.	Z MIN.
YA26	2/0 AWG	125	70mm <sup>2</sup> STR [11]	3/8	M10	1.50 [38]	.83 [21]	.40 [10]	2.77 [70]	.41 [10]	.56 [14]	.12 [3]	.42 [11]
YA26N				1/2	M12		.83 [21]	.56 [14]	3.21 [82]	.63 [16]	.56 [14]	.12 [3]	.64 [16]
YA26TC14				1/4	M6		.83 [21]	.27 [7]	2.58 [66]	.31 [8]	.56 [14]	.12 [3]	.32 [8]
YA26TC516				5/16	M8		.83 [21]	.33 [8]	2.65 [67]	.34 [9]	.56 [14]	.12 [3]	.35 [9]
YA27	3/0 AWG	150	-----	1/2	M12	1.50 [38]	.91 [23]	.53 [13]	3.06 [78]	.53 [13]	.62 [16]	.13 [3]	.55 [14]
YA27N				1/2	M12		.91 [23]	.56 [14]	3.25 [82]	.63 [16]	.62 [16]	.13 [3]	.64 [16]
YA28TC14	4/0 AWG	200	-----	1/4	M6	1.62 [41]	1.02 [26]	.27 [7]	2.79 [71]	.31 [8]	.69 [18]	.14 [4]	.33 [8]
YA28TC38				3/8	M10	1.62 [41]	1.02 [26]	.40 [10]	2.98 [76]	.41 [10]	.69 [18]	.14 [4]	.42 [11]
YA28				1/2	M12	1.62 [41]	1.02 [26]	.53 [13]	3.23 [82]	.53 [13]	.69 [18]	.14 [4]	.55 [14]
YA28N				1/2	M12	1.62 [41]	1.02 [26]	.56 [14]	3.41 [87]	.63 [16]	.69 [18]	.14 [4]	.64 [16]

CONNECTOR SIZE	TOLERANCES					
	B	C	K DIA.	L	N	O.D.
-8C THRU -25	±.06	±.04	±.02	±.09	±.03	±.01
-26 THRU -34	±.08	+ .04 - .06	±.02	±.12	±.03	±.01
-35 AND UP	±.09	±.06	±.02	±.15	±.06	±.01

TOLERANCE BLOCK

INSTALLATION TOOLING (# CRIMPS)

CATALOG NO.	COLOR CODE	DIE INFORMATION		MECHANICAL				HYDRAULIC					DIELESS (# CRIMPS)	WIRE STRIP LENGTH		
		DIE INDEX	TYPE	YIMRTC 6	OUR840	MD6 MD7	MD6--R2 MD7-34R	PATMD6 PAT600 Y500CT	Y34A Y34B Y34BH 8 5	Y35, Y39 Y750, PAT750 5	Y46, PAT46 4 5	Y45 3 5			Y48B	Y60BHU
YA26 YA26N YA26TC14 YA26TC516	BLACK	13	BLACK DIE SET NEST INDENTOR	-----	X26RT(4)	W26RT(4) W26VT(4)	W26RT(4) W26VT(4)	W26RT(4) W26VT(4)	-----	U26RT(2)	U26RT(2)	U26RT(2)	-----	-----	MECHANICAL: MY29-3(2) MY29-11(2) MRC840(4)	1-9/16"
YA27 YA27N	ORANGE	14	ORANGE DIE SET NEST INDENTOR	-----	X27RT(6)	W27RT(4) W27VT(4)	W27RT(4) W27VT(4)	W27RT(4) W27VT(4)	-----	U27RT(2)	U27RT(2)	U27RT(2)	-----	-----		
YA28TC14 YA28TC38 YA28 YA28N	PURPLE	15	PURPLE DIE SET NEST INDENTOR	-----	X28RT(6)	W28RT(4) W28VT(4)	W28RT(4) W28VT(4)	W28RT(4) W28VT(4)	-----	U28RT(2)	U28RT(2)	U28RT(2)	C28R (2) L28RT (1)	-----	1-11/16"	
				-----	-----	-----	-----	-----	B28D(1) A28D(1) Y34PR	U28D-1(1) Y34PR	U28D-1(1) Y34PR	U28D-1(1) Y34PR	C28D (1) Y48PR	-----		

NOTES:

- MATERIAL : COPPER TUBING.
- FINISH: ELECTRO-TIN PLATED.
- CATALOG # PT6515 ADAPTOR IS REQUIRED TO USE "U" DIES IN Y45 SERIES TOOLS.
- CATALOG # PUADP-1 ADAPTOR IS REQUIRED TO USE "U" DIES IN Y46 SERIES TOOLS.
- Y35P3 INDENTOR ADAPTOR REQUIRED FOR Y34PR INDENTOR.
- PERMANENT DIE IN TOOLING.
- DIMENSIONS IN BRACKETS [ ] ARE IN MILLIMETERS ROUNDED OFF TO THE NEAREST MILLIMETER, UNLESS OTHERWISE NOTED, AND ARE FOR REFERENCE ONLY.
- FOR USE BY CUSTOMERS THAT HAVE THIS HYPRESS™. NO NEW Y34A HYPRESSES™ ARE BEING PROCESSED. Y34A USES A--D NEST DIES ONLY.
- CONNECTORS ARE UL LISTED; UNDRILLED VERSIONS ARE NOT UL LISTED.
- CONNECTORS ARE CSA CERTIFIED; UNDRILLED VERSIONS ARE NOT CSA CERTIFIED.
- FOR UNDRILLED VERSIONS ADD SUFFIX "U" TO END OF CATALOG NUMBER. FOR UNDRILLED VERSIONS, USE D MIN. = N MAX. + Z MIN.
- "X", "W-RT", "W-VT", "U", & "L" DIE SETS ARE COLOR CODED. "A", "B", AND "C" DIES ARE NOT COLOR CODED. NESTS AND INDENTOR TYPE ARE NOT COLOR CODED.
- FOR NICKEL PLATING ADD SUFFIX "NK" TO THE CATALOG NUMBER. NICKEL PLATED VERSIONS ARE UL & CSA LISTED.

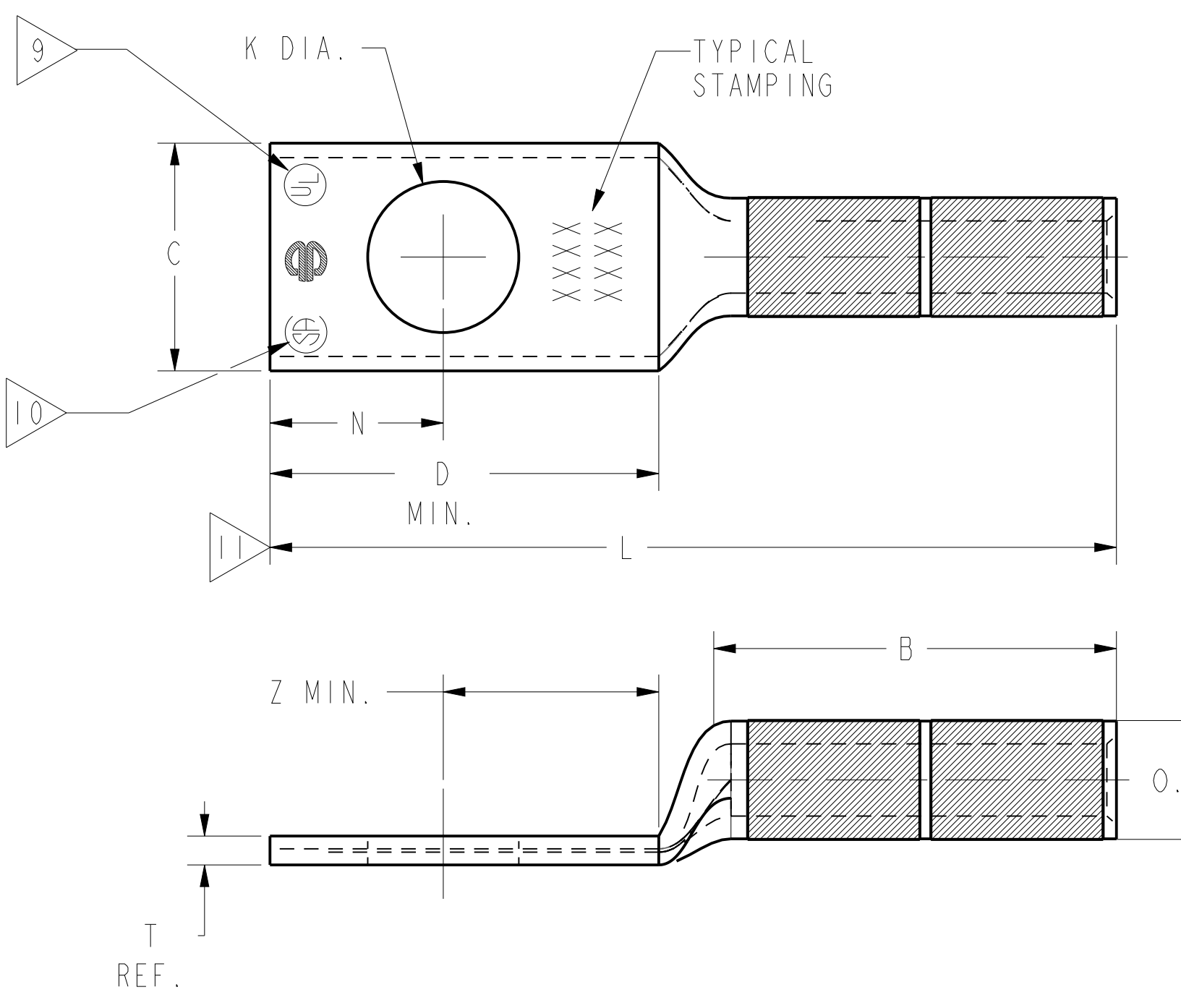

REFERENCE: SD17179, (YA-2, YA-4) SE209241

HYLUG™			
ITEM NO:	N/A		
CAT. NO:	YA-, YA-N, YA-TC-		
DRAWN BY:	C. RACANO	6/16/77	
CHECKER:	CAR	6/16/77	
DSN APPVL:	R ROMAN	10/11/14	
MFG APPVL:	N/A	--	
QA APPVL:	C KOWALCZYK	10/22/14	
MKT APPVL:	K BOUTIN	10/8/14	
PROD FAM:	--	DRAWING NO	REV
PROJECT #:	DO 37810	SIZE	SD079849
DOCUMENT TYPE:	Sales		F
REL LEVEL:	Released		SHEET 4 OF 10

REV: PE0200